

Features

- Hollow shaft absolute encoder in single- resp. multiturn- version
- **Resolution:**
max. 24 Bit (multiturn)
max. 15 Bit (singleturn)
- Mounting at torque support
- Specification of interface SSI (synchron serial interface)
- Self-diagnosis
- Electronical preset setting
- Connector version
- optional incremental signals

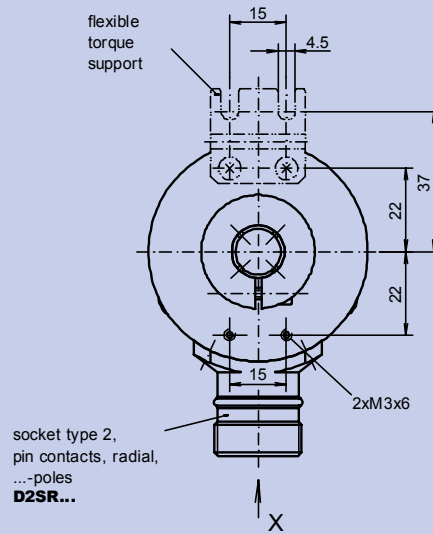

drawing-no.: 028- 5 Y 7

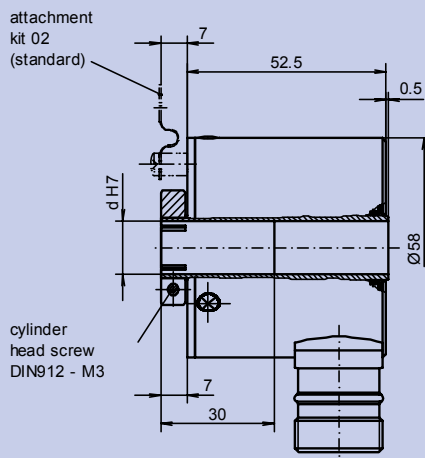

Mechanical data

Design	A 4	A 4
Housing	aluminium	
Protection	IP 65	according to DIN EN 60 529 IP65
Construction principle	LED with glass slotdisc Electronical count with buffer (multiturn)	
max. revolution (mechanical)	$n_{max} \leq 8000 \text{ min}^{-1}$	
Permissible motor-shaft play	axial $\leq 0.25 \text{ mm}$ radial $\leq 0.1 \text{ mm}$	(at shaft end)
Starting torque	at 20 °C $\leq 2 \text{ Ncm}$	
Vibration	55... 2000 Hz $\leq 100 \text{ m/s}^2$	according to DIN IEC 60 068, part 2-6
Shock	11 ms $\leq 300 \text{ m/s}^2$	according to DIN IEC 60 068, part 2-27
Hollow shaft diameter	d 12 mm	(standard), 10 mm, 14 mm possible 14
Weight	approx. 325 g	

Electrical data

Steps per revolution	Single-/Multiturn	programmable* up to max. 32.768 (15 Bit) steps per revolution	XX
Number of turns	Multiturn	programmable* up to max. 16.777.216 (24 Bit) shaft turns	YY
Electronic version	serial	SSI (synchron serial interface)	SS
Output code (programmable)*		Gray-Code (factory setting) Binary-Code	GR BI
Supply voltage	U_B	10-30 VDC (polarity protected)	
Current consumption (no-load)	I_{max}	≤ 70 mA (at 24 VDC)	
Inputs		control signal: V/R, Reset SSI: optocoupler inputs for electrical isolation	
Outputs		level high $\geq U_B - 3.5$ V (at $I = -20$ mA) load high ≤ -20 mA SSI: RS-485 (2-wires) level low ≤ 0.5 V (at $I = 20$ mA) load low ≤ 20 mA	
Clock frequency	f_T	80 kHz to 1 MHz	
Monoflop time		16-26 μ s	
Type of connection		socket type 2, pin contacts, radial, 12-poles socket type 2, pin contacts, radial, 17-poles (SSI + Inkrementalsignale)	D2SR12 D2SR17
Operating temperature range		-20 °C to +85 °C	S
Permissible relativ humidity		≤ 90 % (condensation not permitted)	

Options

Incremental output signals	A, B	2 sine-wave signal trains phase shifted by 90° electr., 2048 (4096 optional) periods/rev., output amplitude: 1 V_{pp} at $Z_0 = 120 \Omega$ (TTL- / HTL- level optional)
----------------------------	------	--

Connection table

SSI

PIN-no.	signals	PIN-no.	signals
PIN 1	clock -	PIN 7	reset
PIN 2	clock +	PIN 8	V/R
PIN 3	data +	PIN 9	NC
PIN 4	data -	PIN 10	error
PIN 5	NC	PIN 11	+ U_B
PIN 6	NC	PIN 12	0 V

SSI + Incremental signals

PIN-no.	signals	PIN-no.	signals
PIN 1	clock -	PIN 10	error
PIN 2	clock +	PIN 11	+ U_B
PIN 3	data +	PIN 12	0 V
PIN 4	data -	PIN 13	NC
PIN 5	NC	PIN 14	A +
PIN 6	NC	PIN 15	A -
PIN 7	reset	PIN 16	B +
PIN 8	V/R	PIN 17	B -
PIN 9	NC		

Specification of the connections

PIN Explanation

7	reset	Reset input for setting zero position value at any desired point within the entire revolution. The resetting process is triggered by apply of + U_B .
8	V/R	Up/down counting direction input: + U_B or NC = increasing code values with a clockwise shaft rotating direction when looking at the mounting side. 0 V = decreasing code values with a clockwise shaft rotating direction when looking at the flange side.
10	error	Diagnostic-output (open collector). The output is high-active, that means if no fault submitted, is the output to 0 V interconnected.

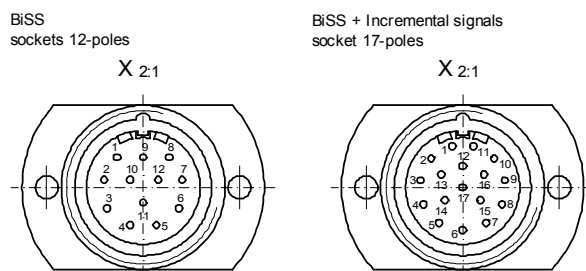

Ordering example

ATD 2S Absolute encoder ATD 2S	A 4 Design A 4	Y 7 Mechanical variant Y 7 = loka at the drawing	13/12 Steps / rev. / No. of turns 8192 (13 Bit) steps/rev. 4096 (12 Bit) rev.	SS Electronic version SSI (synchron serial)	GR Output code Gray-Code	D2SR12 Type of connection socket type 2, pin contacts, radial, 12-poles	S Operating temperature -20 °C to +85 °C	12 Shaft diameter 12 mm	IP65 Protection IP65	02 Attachment kit variant 02
---	-----------------------------	---	---	--	---------------------------------------	---	---	--------------------------------------	-----------------------------------	---