

**Features**

- Hollow shaft absolute encoder in single- resp. multiturn version
- **Programmable resolution:**  
max. 8.192 steps/revolution  
max. 65.536 shaft turns  
(only multiturn)
- Mounting at torque support
- Programmable operating modes
- Programmable preset value
- Bus cover detachable

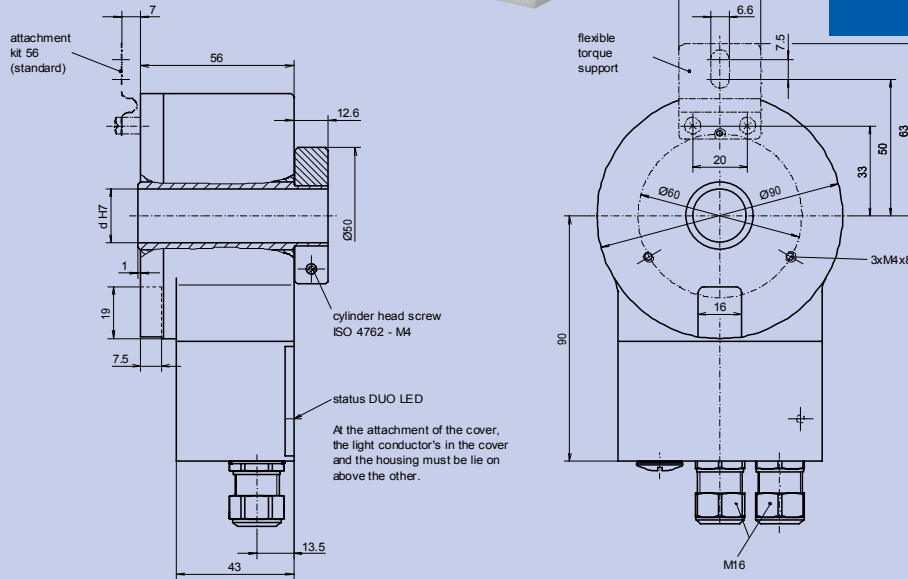
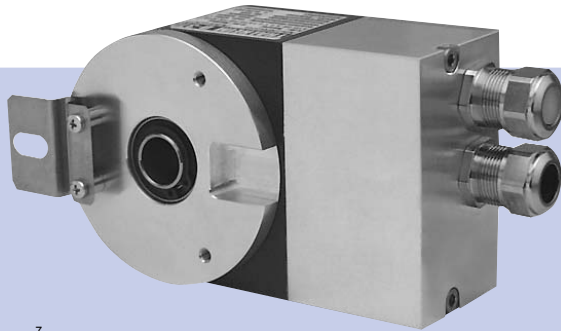

Drawing-no.: 034-13 Y 3

**CAN**

**Mechanical data**

Design style	A 4		A 4
Housing	housing	light-alloy metal, unpainted	
	flange	light-alloy metal, unpainted	
Protective class	IP 54	according to DIN EN 60 529	IP54
Construction principle	LED with glas slotdisc electrical count with buffer (multiturn)		
max. revolution	mechanical	$n_{max} \leq 3.800 \text{ rpm}$	
	electrical	$n_{max} \leq 6.000 \text{ rpm}$	
Permissible motor-shaft play	axial	$\leq 0.25 \text{ mm}$	(at shaft end)
	radial	$\leq 0.1 \text{ mm}$	
Starting torque	at 20° C	$\leq 7 \text{ Ncm}$	
Vibration	16... 2.000 Hz	$\leq 200 \text{ m/s}^2$	according to DIN IEC 60 068, part 2-6
Shock	6 ms	$\leq 2.000 \text{ m/s}^2$	according to DIN IEC 60 068, part 2-27
Moment of inertia (rotor)	$200 \times 10^{-6} \text{ kgm}^2$		
Shaft diameter	d	20 mm (standard)	15 mm, 16 mm, 18mm, 25 mm, 25.4 mm possible 20
Weight	approx. 830 g		

## Electrical data

Steps per revolution	Single-/Multiturn	<b>programmable</b> up to max. 8.192 (13 Bit) steps per revolution	<b>XX</b>
Number of turns	Multiturn	<b>programmable</b> up to max. 65.536 (16 Bit) shaft turns	<b>YY</b>
Output code		Binär-Code	<b>BI</b>
Accuracy		±0.025 Grad at 400 kHz ± 0.05 Grad at 800 kHz	
Supply voltage	$U_B$	10-30 VDC (poling error safe)	
Input current (without load)	$I_{max}$	≤ 100 mA (at 24 VDC)	
Baud rate		9.6 kBaud to 12 Mbaud	
Type of connection		detachable bus cover with 2 x M16	<b>M16</b>
Operating temperature range		-20 °C to +85 °C	<b>S</b>
Permissible relative humidity		≤ 90 % (condensation not permitted)	
Address		settable with rotary switch (factory setting 00)	
Rotating direction		clockwise (cw) when the flange is viewed from the front (programmable)	
Electrical connection		The electrical connection and the bus cover may not be attached or removed under voltage.	

## CANopen features

Bus protocol	CANopen	<b>CB</b>
Device-profile	CANopen - CiA DSP 406	<b>CO</b>
CANopen features	Device class 2	
Operating modes	Polling Mode (asynch, via SDO), cyclic Mode (asynch-cyclic), Synch Mode (synch-cyclic), Acyclic Mode (synch-acyclic)	
Preset value	With the „Preset“ parameter the encoder can be set to a desired actual process value.	
Parameter functions	Rotating direction: With the operating parameter the rotating direction in which the output code is to increase or decrease can be parameterized. Scaling: The steps per revolution and the total revolution can be parameterized.	
Diagnosis	The encoder supports the following error messages: Position error, parameter error, Lithium cell voltage at lower limit (multiturn)	
Default setting	10 kbit/s, node number 0	

### View inside bus cover

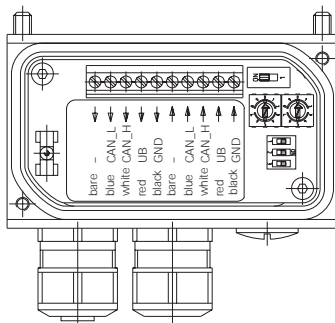

### Settings of terminating resistors

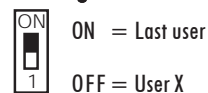

### Settings of user address

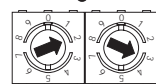

Address can be set with rotary switch.  
Example: User address 23

### Connection tabel

CAN\_L Negative serial data line, pair 1 and pair 2  
CAN\_H Positive serial data line, pair 1 and pair 2  
 $U_B$  Supply voltage 10 - 30 VDC  
GND Ground contact for  $U_B$   
(Terminals with the same designation are internally interconnected)

### Setting baud rate



Baud rate	Setting Dip-Switch		
	1	2	3
10 kBit/s	OFF	OFF	OFF
20 kBit/s	OFF	OFF	ON
50 kBit/s	OFF	ON	OFF
125 kBit/s	OFF	ON	ON
250 kBit/s	ON	OFF	OFF
500 kBit/s	ON	OFF	ON
800 kBit/s	ON	ON	OFF
1 MBit/s	ON	ON	ON

## Ordering example

<b>ATD 5B</b>	<b>A 4</b>	<b>Y 3</b>	<b>13/16</b>	<b>CB</b>	<b>CO</b>	<b>M16</b>	<b>S</b>	<b>20</b>	<b>IP54</b>	<b>56</b>
Absolute encoder ATD 5B	Design style A 4	Mechanical variante Y 3 = look at the drawing	Steps / rev. / No. of turn 8.192 (13 Bit) steps/rev. 65.536 (16 Bit) rev.	Datatransmission CAN-Bus	Data protocol CANopen-profile	Type of connection Bus cover with 2xM16	Operating temperature -20 °C to +85 °C	Shaft diameter 20 mm	Protective class IP54	Attachment kit variante 56