

Incremental Encoder with shaft

ITD 01 B14



Qualities :

- Mini-incremental encoder
- **Number of pulses**, up to **600** pulses per revolution
- housing diameter $\varnothing 24$
- TTL- or HTL-output signals
- Cable outlet radial

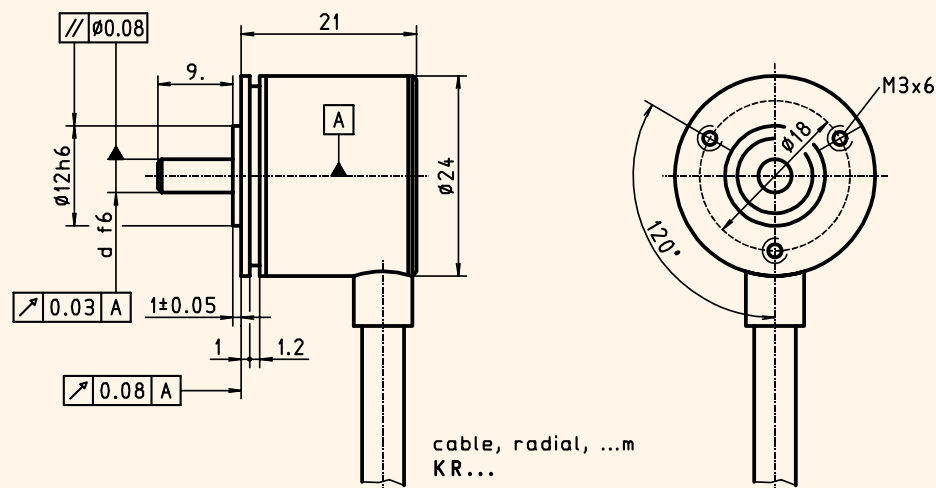
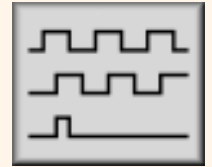

ITD 01 B14

drawing-no.: 030 - 8

Mechanical data:

Housing		light-alloy metal, unpainted
Design style	B14	B14
Protective class	IP54	IP 54
Construction principle		LED with slotdisc
max. revolution (mechanical)	n_{max}	≤ 18000 rpm
Admissible shaft load	axial	≤ 10 N
	radial	≤ 20 N
	at 20 ° C	≤ 0.6 Ncm
Starting torque		≤ 100 m/s ²
Vibration	55... 2000 Hz	≤ 300 m/s ²
Shock	11 ms	approx. 2 gcm ²
Moment of inertia (rotor)		4 mm
Shaft diameter	d	approx. 50 g
Weight		

according to DIN 40 050, IEC 529
(observe frequency limit)
(at shaft end)
according to DIN IEC 68, part 2-6
according to DIN IEC 68, part 2-27

Incremental Encoder with shaft

ITD 01 B14



Electrical data:

• Number of pulses	Z	XXXX	360 pulses per revolution
• Execution of electronic	TTL	T	TTL-output signals supply voltage: $U_B = 5 \text{ VDC} \pm 5\%$ (poling error safe) output amplitude: $U_{\text{LOW}} \leq 0.5 \text{ V}$ $U_{\text{HIGH}} \geq 2.5 \text{ V}$
	HTL	H	HTL-output signals supply voltage: $U_B = 8 - 30 \text{ VDC}$ (poling error safe) output amplitude: $U_{\text{LOW}} \leq 1.5 \text{ V}$ $U_{\text{HIGH}} \geq U_B - 3 \text{ V}$
• Output signals	A, B	BX	2 square-wave pulse trains phase shifted by $90^\circ (\pm 10^\circ)$ electr. (<i>refere to output signals-diagram</i>) pulse : pause = 1 : 1 $\pm 10\%$ at 30 kHz $\geq 15 \text{ V}/\square\text{s}$
Pulse ratio			100 kHz
Flank steepness			$\leq 30 \text{ mA}$
Frequency limit	f_G		$\leq 25 \text{ mA}$ (without load)
Output load current	I_{Load}		$\leq 100 \text{ m}$ (Thalheim-cable)
Input current	I_{max}		$\leq 100 \text{ m}$ (standard length)
Permissible cable length			
• Type of connection		KR1	cable, radial, 1.0 m
• Operating temperature range		S	-20 °C to +85 °C

Optionen:

• Output signals	A, B, N	NX	2 square-wave pulse trains phase shifted by $90^\circ (\pm 10^\circ)$ electr. + zero pulse, 90° electr. lenght (<i>refere to output signals-diagram</i>)
	A, B, N	SX	2 square-wave pulse trains phase shifted by $90^\circ (\pm 10^\circ)$ electr. + zero pulse, $180^\circ (\pm 10^\circ)$ electr. lenght (<i>refere to output signals-diagram</i>)

Connection table:

wire color	=	signals
green	=	A
yellow	=	B
grey	=	N
brown	=	+ U_B
white	=	0 V
transparent	=	shilding

Output signal diagram:

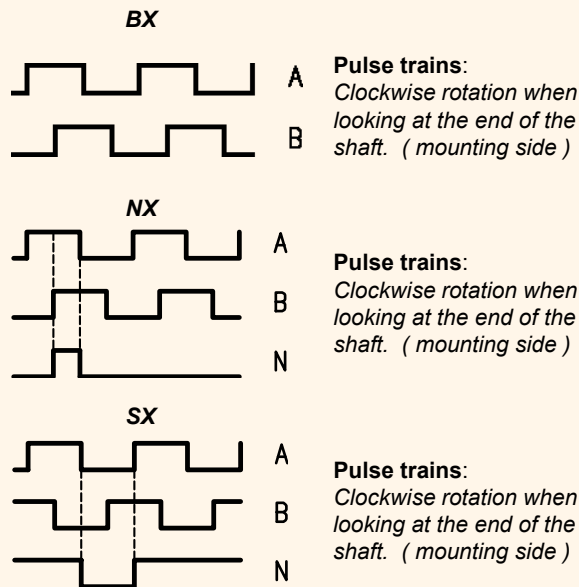

Ordering example:

ITD 01	B14		360	H	BX	KR1	S	4	IP54	
Incremental encoder ITD 01	Design style B14	Mechanical variante Y... = look at the drawing	Number of pulses 360 pulses / revolution	Execution of electronic $U_B = 8-30 \text{ VDC HTL-output}$	Output signals A-, B-track	Type of connection cable, radial, 1 m	Operating temperature 20 °C to +85 °C	Shaft diameter 4 mm	Protective class IP 54	Attachment kit variante