

Incremental Encoder with hollow shaft

ITD 40 A 4



Qualities :

- Low cost hollow shaft incremental encoder
- **Number of pulses**, up to **1024** pulses per revolution
- Mounting at torque support
- TTL- or HTL-output signals
- Cable outlet radial or axial
- Connector versions optional
- Hollow shaft going through optional

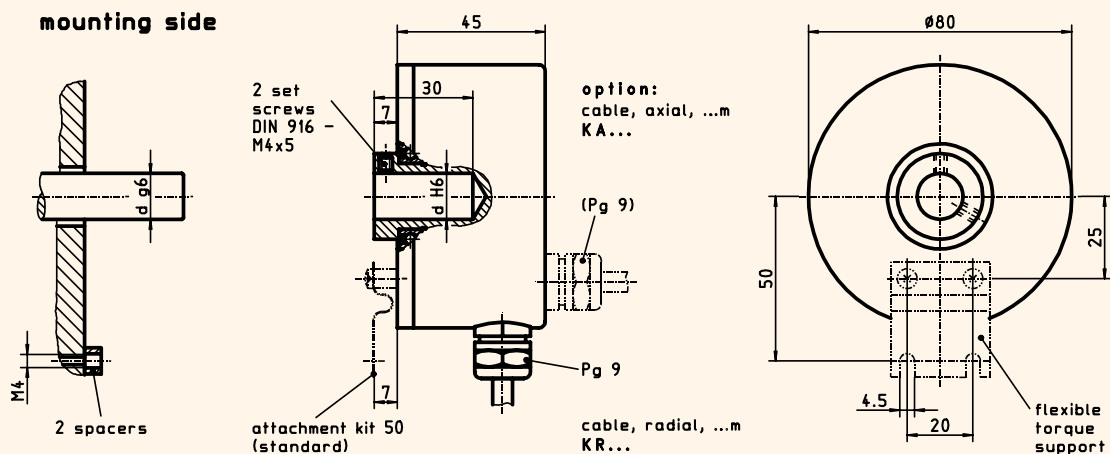
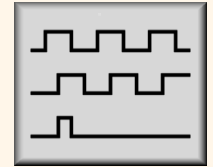

ITD 40 A 4

drawing-no.: 026 - 5

Mechanical data:

Housing		light-alloy metal, black, powder coated
Design style	A 4	A 4
Attachment kit	50	50 (standard) (ref. datasheet "Attachment kit's ...")
Protective class	IP65	IP 65 according to DIN 40 050, IEC 529
Construction principle		OPSIC with slotdisc
max. revolution (mechanical)	n_{max}	≤ 8000 rpm (observe frequency limit)
Admissible motor-shaft play	axial	≤ 0.25 mm
	radial	≤ 0.1 mm
Starting torque	at 20 ° C	≤ 1.5 Ncm
Vibration	55... 2000 Hz	≤ 100 m/s ²
Shock	11 ms	≤ 1000 m/s ²
Hollow shaft diameter	d	15 mm (standard) according to DIN IEC 68, part 2-27 (10 to 16 mm possible)
Weight		approx. 550 g

Incremental Encoder with hollow shaft

ITD 40 A 4



Electrical data:

• Number of pulses	Z	XXXX	100, 180, 200, 360, 400, 500, 512, 720, 1000, 1024 pulses/rev.
• Execution of electronic	TTL	T	TTL-output signals supply voltage: $U_B = 5 \text{ VDC} \pm 5\%$ (poling error safe) output amplitude: $U_{\text{LOW}} \leq 0.5 \text{ V}$ $U_{\text{HIGH}} \geq 2.5 \text{ V}$ <i>line driver-output stage</i>
	HTL	H	HTL-output signals supply voltage: $U_B = 8 - 30 \text{ VDC}$ (poling error safe) output amplitude: $U_{\text{LOW}} \leq 1.5 \text{ V}$ $U_{\text{HIGH}} \geq U_B - 3 \text{ V}$ <i>push pull-output stage</i> (shortening proof)
• Output signals	A, B + Inv.	BI	2 square-wave pulse trains phase shifted by $90^\circ (\pm 10^\circ)$ electr. + inverting pulse : pause = 1 : 1 $\pm 10\%$ at 30 kHz (<i>refere to output signals-diagram</i>)
Pulse ratio			
Flank steepness			
Frequency limit	f_G		120 kHz
Output load current	I_{Load}		$\leq 70 \text{ mA}$
Input current	I_{max}		$\leq 100 \text{ mA}$ (without load)
Permissible cable length			$\leq 100 \text{ m}$ (Thalheim-cable)
• Type of connection		KR1	cable, radial, 1.0 m (standard length)
• Operating temperature range		S	- 20 °C to + 70 °C

Options:

• Execution of electronic		R	TTL-output signals supply voltage: $U_B = 8 - 30 \text{ VDC}$ (poling error safe) <i>line driver-output stage</i>
• Output signals	A, B, N + Inv.	NI	2 square-wave pulse trains + zero pulse, 90° electr. + inverting
• Type of connection	cable	KA...	cable, axial, ... m
	connector	D2SA12	socket type 2, pin contacts, axial, 12-poles
	connector	D2SR12	socket type 2, pin contacts, radial, 12-poles
	connector	...	performed at cable (ref. data sheet Type of performed cables)
• Operating temperature range		E	- 20 °C to + 100 °C

Accessories:

Connector, for version **D2S..12**

S2BG12 connector type 2, bush contacts, straight, 12-poles

Connection table:

wire color	PIN-no.	signals
brown	PIN 5	= A
green	PIN 6	= A inverted
grey	PIN 8	= B
pink	PIN 1	= B inverted
red	PIN 3	= N
black	PIN 4	= N inverted
brown 0.5 mm ²	PIN12	= +U _B
white 0.5 mm ²	PIN10	= 0 V
blue	PIN2	= +U _{sensor}
white	PIN11	= 0 V _{sensor}
	PIN7	= NC
transparent	PIN9	= shilding/housing

Output signal diagram:

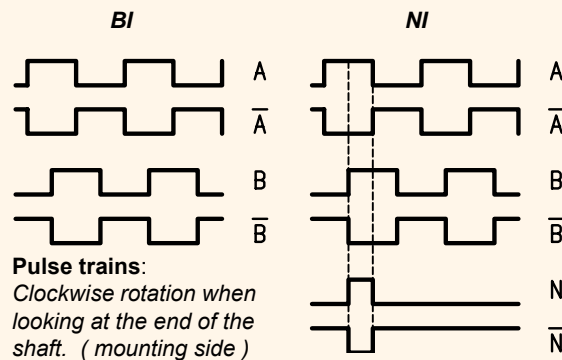

Ordering example:

ITD 40	A 4		1024	H	BI	KR1	S	15	IP65	50
Incremental encoder ITD 40	Design style A 4	Mechanical variante Y... = look at the drawing	Number of pulses 1024 pulses / revolution	Execution of electronic U _B = 8-30 VDC HTL-output	Output signals A-, B-track + inverting	Type of connection cable, radial, 1 m	Operating temperature 20 °C to +70 °C	Hollow shaft diameter 15 mm	Protective class IP 65	Attachment kit variante 50