

Incremental Encoder with shaft

ITD 41 B10



Qualities:

- Robust incremental encoder for industrial use
- **Number of pulses**, up to **6000** pulses per revolution
- *Euro-flange* mounting
- Centering seat $\varnothing 85$, mounting punch circle $\varnothing 100$
- TTL- or HTL-outputsignals
- Cable outlet radial or axial
- Connector versions optional
- Cable-box versions optional

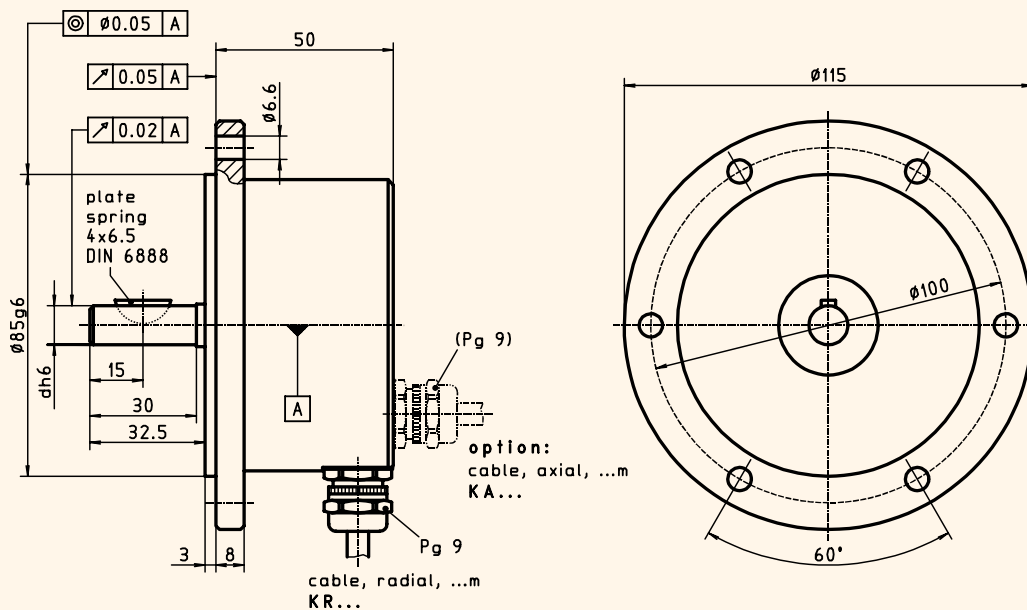
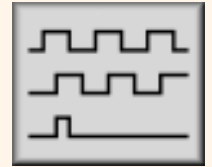

ITD 41 B10

drawing-no.: 025 - 7

Mechanical data:

Housing		light-alloy metal, unpainted	
Design style	B10	B10	
Protective class	IP65	IP 65	according to DIN 40 050, IEC 529
Construction principle		LED with glas slotdisc	
max. revolution (mechanical)	n_{max}	$\leq 12000 \text{ min}^{-1}$	(observe frequency limit)
Admissible shaft load	axial	$\leq 40 \text{ N}$	
	radial	$\leq 60 \text{ N}$	(at shaft end)
Starting torque	at 20 ° C	$\leq 1.2 \text{ Ncm}$	
Vibration	50... 2000 Hz	$\leq 100 \text{ m/s}^2$	according to DIN IEC 68, part 2-6
Shock	11 ms	$\leq 300 \text{ m/s}^2$	according to DIN IEC 68, part 2-27
Moment of inertia (rotor)		approx. 60 gcm ²	
Shaft diameter	d	11 mm	
Weight		approx. 850 g	

Incremental Encoder with shaft

ITD 41 B10



Electrical data:

• Number of pulses	Z	XXXX	1000 bis 6000 pulses per revolution
• Execution of electronic	TTL	T	TTL-output signals supply voltage: $U_B = 5 \text{ VDC} \pm 5\%$ (poling error safe) output amplitude: $U_{LOW} \leq 0.5 \text{ V}$ $U_{HIGH} \geq 2.5 \text{ V}$
	HTL	H	HTL-output signals supply voltage: $U_B = 8 - 30 \text{ VDC}$ (poling error safe) output amplitude: $U_{LOW} \leq 1.5 \text{ V}$ $U_{HIGH} \geq U_B - 3 \text{ V}$
• Output signals	A, B, N + Inv.	NI	2 square-wave pulse trains phase shifted by 90° ($\pm 10^\circ$) electr. + zero pulse, 90° electr. length + inverting (<i>refere to output signals-diagram</i>) pulse : pause = 1 : 1 $\pm 10\%$ at 30 kHz $\geq 15 \text{ V}/\square\text{s}$
Pulse ratio			
Flank steepness			
Frequency limit	f_G	TTL	300 kHz
Output load current	I_{Load}	TTL	$\leq 70 \text{ mA}$
Input current	I_{max}		$\leq 100 \text{ mA}$
Permissible cable length			$\leq 100 \text{ m}$
• Type of connection		KR1	cable; radial; 1.0 m
• Operating temperature range		S	0°C to $+70^\circ \text{C}$

Options:

• Execution of electronic		R	TTL-output signals supply voltage: $U_B = 8 - 30 \text{ VDC}$ (poling error safe)
• Type of connection	cable	KA...	cable, axial, ... m
	connector	D2SA12	socket type 2, pin contacts, axial, 12-poles
	connector	D2SR12	socket type 2, pin contacts, radial, 12-poles
	connector	...	performed at cable (ref. data sheet Type of performed cables)
• Operating temperature range		E	-20°C to $+100^\circ \text{C}$

Accessories:

Connector, for version D2S..12

S2BG12 connector type 2, bush contacts, straight, 12-poles

Connection table:

wire color	PIN-no.	signals
brown	PIN 5	= A
green	PIN 6	= A inverted
grey	PIN 8	= B
pink	PIN 1	= B inverted
red	PIN 3	= N
black	PIN 4	= N inverted
brown 0.5 mm ²	PIN 12	= + U_B
white 0.5 mm ²	PIN 10	= 0 V
blue	PIN 2	= + U_{sensor}
white	PIN 11	= 0 V _{sensor}
	PIN 7	= NC
transparent	PIN 9	= shilding/housing

Output signal diagram:

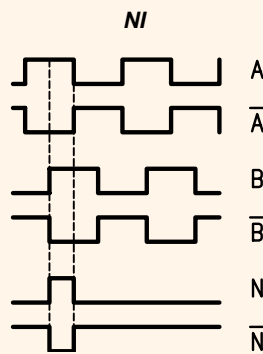

Pulse trains:
Clockwise rotation when looking at the end of the shaft. (mounting side)

Ordering example:

ITD 41	B10		2500	H	NI	KR1	S	11	IP65	
Incremental encoder ITD 41	Design style B10	Mechanical variante Y... = look at the drawing	Number of pulses 2 500 pulses / revolution	Execution of electronic $U_B = 8-30 \text{ VDC}$ HTL-output	Output signals A-, B-, N-track + inverting	Type of connection cable, radial, 1 m	Operating temperature 0°C to $+70^\circ \text{C}$	Shaft diameter 11 mm	Protective class IP 65	Attachment kit variante