

SINMUX® Sine wave Incremental Encoder

ITD 22 A 4 Y47



Qualities :

- Sinusoidal hollow shaft-incremental encoder with **absolute track**
- For the absolute track, no separate control- and data wirings required
- Compact design
- Hollow shaft going through
- Mounting about torque arm
- Sine wave output signals 1 V_{SS}
- Socket radial

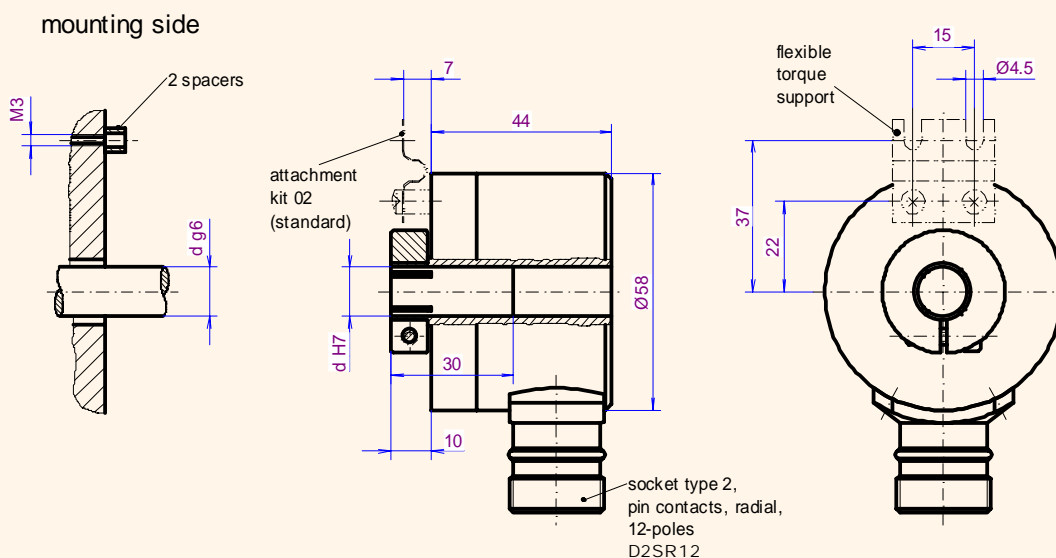
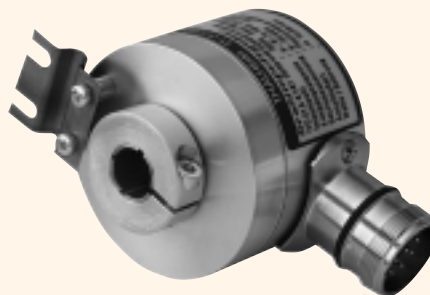
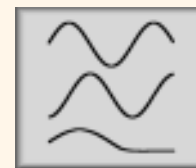

ITD 22 A 4 Y47

drawing-no.: 029 - 1 Y47

Mechanical data:

Housing		light-alloy metal, unpainted	
Design style	A 4	A 4	
Protective class	IP65	IP65	according to DIN 40 050, IEC 529
Construction principle		LED with glas slotdisc	
max. revolution (mechanical)	n_{max}	≤ 8000 rpm	(observe frequency limit)
Admissible shaft load	axial	≤ 0.25 mm	
	radial	≤ 0.1 mm	(at shaft end)
Starting torque	at 20 °C	≤ 1 Ncm	
Vibration	55... 2000 Hz	≤ 100 m/s ²	according to DIN IEC 68, part 2-6
Shock	11 ms	≤ 300 m/s ²	according to DIN IEC 68, part 2-27
Hollow shaft diameter	d	10, 12, 14 mm	
Weight		approx. 400 g	

SINMUX[®] Sine wave Incremental Encoder

ITD 22 A 4 Y47



Electrical data:

• Number of pulses	Z	XXXX	2048 pulses per revolution (further on request)
• Execution of electronic		M	sinusoidal-output signals <i>with amplifier stage</i>
			supply voltage: $U_B = 5 \text{ VDC} \pm 10\%$ (poling error safe)
			output amplitude A+B : appr. $1 V_{SS}$ at $Z_0 = 120 \Omega$
			output amplitude N : appr. $0,4 \text{ V}$ (useable part) at $Z_0 = 120 \Omega$
• Absolute track		P3	for 3-pole pair Antrieb (P3 = 6-poles)
Output signals	A, B, N, Absolute + Inv.		2 sinusoidal-wave signal trains phase shifted by 90° electr.
			+ zero pulse + 2 absolute tracks 120° mech. length
			+ signal inverting (<i>refere to output signals diagram</i>)
Frequency limit	f_G		180 kHz (- 3 dB)
Input current	I_{max}		$\leq 100 \text{ mA}$
• Type of connection		D2SR12	socket type 2, pin contacts, radial, 12-poles
• Operating temperature range		S	0°C to $+85^\circ \text{C}$

Output signal diagram:

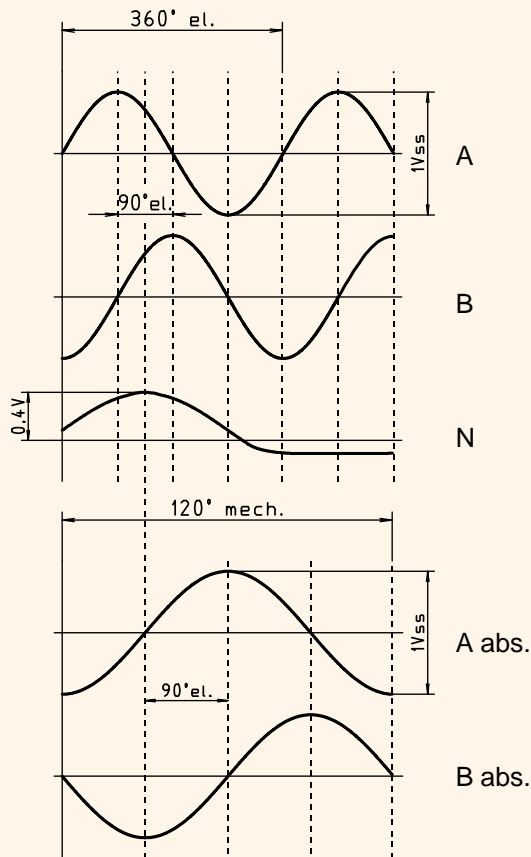

Block diagram:

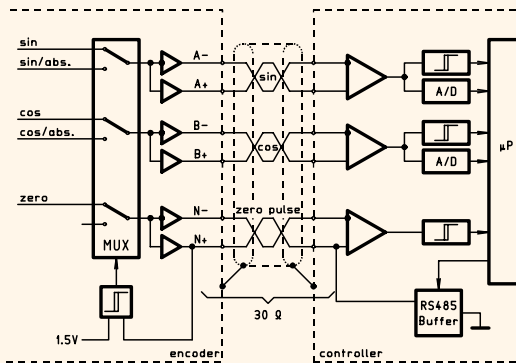

The Sinusoidal-encoder in normal operation delivers signals indicated and printed on the dataplate in difference technology using signalamplitudes of $1 V_{SS}$. To determine the absolute position of the encoder, it is necessary to draw the output of the N+ track (zero pulse) via the controller definded to ground.

Connection table:

PIN-no.	signals
PIN 1	= A + / A + abs.
PIN 2	= A - / A - abs.
PIN 3	= B + / B + abs.
PIN 4	= B - / B - abs.
PIN 5	= N +
PIN 6	= N -
PIN 7	= + U_B
PIN 8	= 0 V

} switchable via N+ track

Ordering example:

ITD 22	A 4	Y47	2048	M	P3	D2SR12	S	12	IP65	02
Incremental encoder ITD 22	Design style A 4	Mechanical variante Y47 = look at the drawing	Number of pulses 2048 pulses / revolution	Execution of electronic signal amplitude = $1,1 V_{SS}$	Output signals A-, B-, N-track + inverting	Type of connection socket type 2, pin contacts, radial, 12-poles	Operating temperature 0°C to $+85^\circ \text{C}$	Shaft diameter 12 mm	Protective class IP 65	Attachment kit variante 02