

Sinusoidal - Incremental Encoder

ITD 22 B14



Qualities :

- High-class incremental encoder for industrial use
- **Number of pulses**, up to **6000** pulses per revolution
- Centering seat $\varnothing 50$, mounting punch circle $\varnothing 68$
- sinusoidal-output signals 1 V_{SS}
- Cable outlet radial or axial
- Connector versions optional

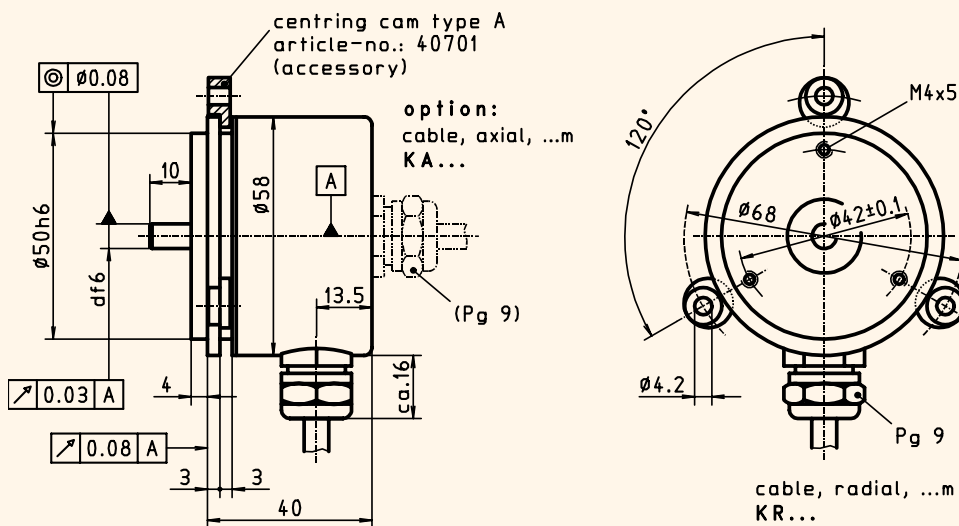

ITD 22 B14

drawing-no.: 027 - 4

Mechanical data:

Housing		light-alloy metal, black, powder coated
Design style	B14	B14
Protective class	IP65	IP 65
Construction principle		LED with glas slotdisc
max. revolution (mechanical)	n_{max}	≤ 12000 rpm
Admissible shaft load	axial	≤ 10 N
	radial	≤ 20 N
	at 20 ° C	≤ 1 Ncm
Starting torque		≤ 100 m/s ²
Vibration	55... 2000 Hz	≤ 300 m/s ²
Shock	11 ms	approx. 15 gcm ²
Moment of inertia (rotor)		6 mm
Shaft diameter	d	approx. 450 g
Weight		

according to DIN 40 050, IEC 529

(observe frequency limit)

(at shaft end)

according to DIN IEC 68, part 2-6

according to DIN IEC 68, part 2-27

Sinusoidal - Incremental Encoder

ITD 22 B14



Electrical data:

• Number of pulses	Z	XXXX	1000 to 6000 pulses per revolution
• Execution of electronic		M	sinusoidal-output signals <i>with amplifier stage</i>
			supply voltage: $U_B = 5 \text{ VDC} \pm 5\%$ (poling error safe)
			output amplitude A+B : appr. $1,1 V_{SS}$ at $Z_O = 120 \text{ k}\Omega$
			output amplitude N : appr. 0.4 V (useable part) at $Z_O = 120 \text{ }\Omega$
• Output signals	A, B, N + Inv.	NI	2 sinusoidal-wave signal trains phase shifted by 90° electr.
			+ zero pulse + signal inverting
			(<i>refere to output singals-diagram</i>)
Frequency limit	f_G		180 kHz (- 3 dB)
Input current	I_{max}		$\leq 170 \text{ mA}$ (without load)
Permissible cable length			$\leq 150 \text{ m}$ (Thalheim-cable)
• Type of connection		KR1	cable, radial, 1.0 m (standard length)
• Operating temperature range		S	0° C to $+85^\circ \text{ C}$

Options:

• Type of connection	cable	KA...	cable; axial; ... m
	connector	D2SA12	socket type 2, pin contacts, axia, 12-poles
	connector	D2SR12	socket type 2, pin contacts, radial, 12-poles
	connector	...	performed at cable (ref. data sheet Type of performed cables)
• Operating temperature range		E	0° C to $+100^\circ \text{ C}$

Accessories:

Connector, for version **D2S..12**
centring cam-set type A (3 pcs.)

S2BG12 connector type 2, bush contacts, straight, 12-poles
article-no.: 40701-3

Connection table:

wire color	PIN-no.	signals
brown	PIN 5	= A +
green	PIN 6	= A -
grey	PIN 8	= B +
pink	PIN 1	= B -
red	PIN 3	= N +
black	PIN 4	= N -
brown 0.5 mm ²	PIN 12	= +U _B
white 0.5 mm ²	PIN 10	= 0 V
blue	PIN 2	= +U _{sensor}
white	PIN 11	= 0 V _{sensor}
	PIN 7	= NC
transparent	PIN 9	= shilding/housing

Output signal diagram:

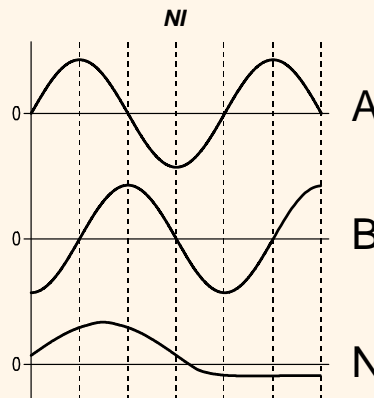

Pulse trains:
Clockwise rotation
when looking at the
end of the shaft.
(mounting side)

Ordering example:

ITD 22	B14		1024	M	NI	KR1	S	6	IP65	
Incremental encoder ITD 22	Design style B14	Mechanical variante Y... = look at the drawing	Number of pulses 1024 pulses / revolution	Execution of electronic signal amplitude = 1,1 V _{SS}	Output signals A-, B-, N-track + inverting	Type of connection cable, radial, 1 m	Operating temperature 0 °C to +85 °C	Shaft diameter 6 mm	Protective class IP 65	Attachment kit variante