

Incremental encoder + DC tachogenerator

ITD 4 + KTD 3-... B10



Qualities:

- Number of pulses, up to 1024 pulses per revolution
- Centering seat $\varnothing 85$, mounting punching circle $\varnothing 100$
- TTL- or HTL-output signals
- Connector outlet optional

+

- High reaction rate
- Small percent ripple

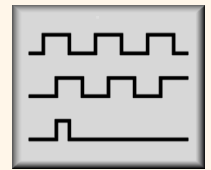
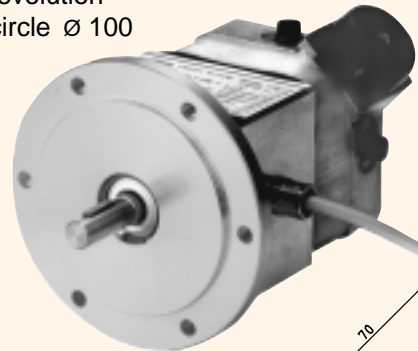

+



commencing in July '99
 New connection cable
 ⇨ new color code
 (see reverse page)

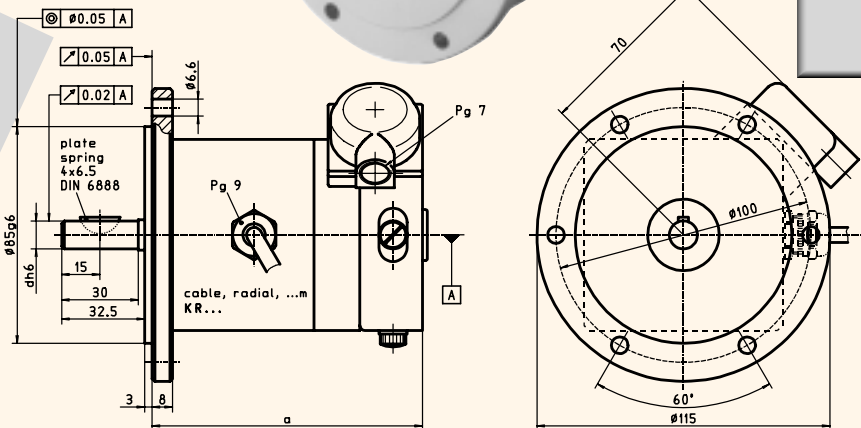

Type	VDC	a
ITD 4... + KTD 3-1 B10	10	106
ITD 4... + KTD 3-2 B10	20	106
ITD 4... + KTD 3-3 B10	30	106
ITD 4... + KTD 3-4 B10	40	116
ITD 4... + KTD 3-6 B10	60	116

ITD 4 + KTD 3-... B10

drawing-no.: 022 - 13

Mechanical data:

Housing		light-alloy metal, unpainted; steel, zined
Design style	B10	B10
Protective class	IP54	IP 54
Construction principle (incremental encoder)		LED with slotdisc
max. revolution (mechanical)	n_{max}	≤ 6000 rpm (observe frequency limit)
Admissible shaft loading	axial	≤ 50 N
	radial	≤ 100 N (at shaft end)
Starting torque	at 20 ° C	≤ 2.5 Ncm
Vibration	50... 2000 Hz	≤ 100 m/s ²
Shock	11 ms	≤ 1000 m/s ²
Shaft diameter	d	11 mm

Electrical data ITD:

• Number of pulses	Z	XXXX	1 up to 1024 pulses per revolution (standard values at requestion)
• Execution of electronic	TTL	T	TTL-output signals
			supply voltage: $U_B = 5$ VDC $\pm 5\%$ (poling error safe)
• Output signals	HTL	H	output amplitude: $U_{LOW} \leq 0.5$ V $U_{HIGH} \geq 2.5$ V
			HTL-output signals
• Output signals	A,B + Inv.	BI	supply voltage: $U_B = 8 - 30$ VDC (poling safe error)
			output amplitude: $U_{LOW} \leq 1.5$ V $U_{HIGH} \geq U_B - 3$ V
Pulse ratio			2 square-wave pulse trains phase shifted by 90° ($\pm 10^\circ$) electr.
Flank steepness			(refer to output signals-diagram)
Frequency limit	f_G	TTL	$\pm 10\%$ at 30 kHz
Output load current	I_{Load}	TTL	≤ 70 mA
		HTL	≤ 70 mA

Incremental encoder + DC tachogenerator

ITD 4 + KTD 3-... B10



Input current (without load) I_{max}		≤ 150 mA
Permissible cable length		≤ 100 m (Thalheim-cable)
• Type of connection	KR1	cable, radial, 1.0 m (standard length)
• Operating temperature range	S	- 20 °C to + 70 °C

Electrical data **KTD**:

referenced at 1000 rpm

Polarity	dependent on rotation direction
Number of pole pair	2 = 4-poles
Number of grooves, segments	29
Grooves frequency	$f_N = \frac{29}{30} * n$
Reversing error	≤ ± 0.1 %
Residual ripple	≤ 0.4 %
Residual ripple frequency	200 Hz
Linearity error	≤ 0.15 %
Regulation range lower limit n_R	0 rpm
Temperature drift (-10 °C to + 100 °C)	± 0.1 % / 10 K (compensated)
Type of connection	terminal box, 2-poles
Isolation class	B
Carbon brushes	4 pieces AG 3 x 4 x 12
Carbon brushes life	approx. 20000 hours of operation
Maintenance	after 10000 hours in service

Type	Rated voltage [VDC]	Rated current [mA]	max. current [mA]	Armature resistance [Ohm]	Upper speed limit [rpm]	Weight [g]
ITD 4 + KTD 3-1	10	10	100	45	6000	2000
ITD 4 + KTD 3-2	20	10	80	170	6000	2000
ITD 4 + KTD 3-3	30	10	80	170	6000	2000
ITD 4 + KTD 3-4	40	10	80	220	4000	2400
ITD 4 + KTD 3-6	60	30	80	220	3000	2400

Options:

• Execution of electronic		R	TTL-output signals	<i>line driver-output stage</i>
• Output signals	<i>A, B, N + Inv.</i>	NI	supply voltage: $U_B = 8 - 30$ VDC (poling error safe)	
• Type of connection	ITD connector	B1BR...	2 square-wave pulse trains + zero pulse, 90° electr. length + inv.	
• Operating temperature range		E	build-in type 1, bush contacts, radial, ...-poles	
• Enhanced protective class			- 20 °C to + 100 °C	

Accessories:

Coupling, for version B1B...	K1SG...	coupling type 1, pin contacts, straight, ...-poles
-------------------------------------	----------------	--

Connection table:

wire color	wire color	signals
New commencing in July '99	Old valid until June '99	
brown	green	= A
green	brown	= A inverted
grey	grey	= B
pink	black	= B inverted
red	pink	= N
black	white	= N inverted
brown 0.5 mm ²	red	= + U_B
white 0.5 mm ²	blue	= 0 V
blue		= + U_{sensor}
white		= 0 V _{sensor}
transparent		= shilding/housing
	yellow	= housing
	transparent	= shilding

Output signal diagram:

